

MYS-6ULX-IND Product Manual

Version V1.0

22-Jan-2017

Version History

Version	Description	Date
V1.0	Initial version	22-Jan-2017

Table of Contents

Table of Contents	3
1.Product Abstract.....	4
2. Hardware Characteristics	6
2.1 CPU Characteristics	6
2.2 Board Resource.....	7
2.3 Extend Header Resource	8
3. Interfaces	9
4. Hardware Design	11
4.1 Power supply	11
4.2 Clock Resources	12
4.3 DDR3L SDRAM.....	12
4.4 eMMC Memory	13
4.5 NAND Flash Memory.....	14
4.6 Ethernet	15
4.7 Micro SD Card	16
4.8 LCD & Touch Panel Interface.....	17
4.9 USB	17
4.10 WIFI	错误!未定义书签。
4.11 Button & LEDs	18
4.12 Boot Configure.....	19
4.13 Expansion Interface.....	21
5. Electronic Characteristics	24
5.1 Operating Temperature	24
5.2 Power Supply Characteristics.....	24
5.3 GPIO DC Characteristics.....	24
6. Mechanical Characteristics	26

1.Product Abstract

The MYS-6ULX-IND is a high-performance low-cost Single Board Computer (SBC) specially designed for Industry 4.0 applications. It is based on NXP i.MX 6UL processor family which features the most efficient ARM Cortex-A7 core and can operate at speeds up to 696 MHz. Each processor in this family provides various memory interfaces, including 16-bit LPDDR2, DDR3, DDR3L, raw and managed NAND flash, NOR flash, eMMC, Quad SPI and a wide range of other interfaces for connecting peripherals.



Figure 1-1 MYS-6ULX-IND Single Board Computer

MYS-6ULX-IND are integrated with rich peripherals including Ethernet, USB OTG, USB Host, TF Card, WIFI, User keys, LED, LCD interface, IO expansion interface and other functions. MYIR is using the 14 x 14mm, 0.8 mm ball pitch, 289MAPBGA package on MYS-6ULX-IND. i.MX 6UL application processor on the MYS-6ULX-IND board provides multiple compatible options of G0, G1, G2 and G3 sub families. The MCIMX6G2CVM05AA is the default part delivered with the board and MYIR offers

customization on optional CPU configuration in bulk orders.

Feature	MCIMX6G0	MCIMX6G1	MCIMX6G2	MCIMX6G3
Speed	528 MHz	528 MHz, 696 MHz	528 MHz, 696 MHz	528 MHz
Cache	32 KB-I, 32 KB-D	32 KB-I, 32 KB-D 128 KB L2	32 KB-I, 32 KB-D 128 KB L2	32 KB-I, 32 KB-D 128 KB L2
OCRAM	128 KB	128 KB	128 KB	128 KB
DRAM	16-bit LP-DDR2, DDR3/DDR3L	16-bit LP-DDR2, DDR3/DDR4L	16-bit LP-DDR2, DDR3/DDR5L	16-bit LP-DDR2, DDR3/DDR6L
eFuse	512-bit	1024-bit	1536-bit	2048-bit
NAND (BCH40)	Yes	Yes	Yes	Yes
EBI	Yes	Yes	Yes	Yes
Ethernet	10/100-Mbit/s x 1	10/100-Mbit/s x 1	10/100-Mbit/s x 2	10/100-Mbit/s x 2
USB	OTG, HS/FS x 1	OTG, HS/FS x 2	OTG, HS/FS x 2	OTG, HS/FS x 2
CAN	0	1	2	2
Security	Basic	TRNG, Crypto Engine (AES/TDES/SHA), Secure Boot	TRNG, Crypto Engine (AES/TDES/SHA), Secure Boot	TRNG, Crypto Engine (AES with DPA/TDES/SHA/RSA), Secure Boot, tamper monitor, PCI4.0 pre-certification, OTF DRAM encryption
Graphic	None	None	PxP	PxP
CSI	None	None	24-bit Parallel CSI	24-bit Parallel CSI
LCD	None	None	24-bit Parallel LCD	24-bit Parallel LCD
Quad SPI	1	1	1	1
SDIO	2	2	2	2
UART	4	8	8	8
I2C	2	4	4	4
SPI	2	4	4	4
I2S/SAI	1	3	3	3
S/PDIF	1	1	1	1
Timer/PWM	Timer x 2, PWM x 4	Timer x 4, PWM x 8	Timer x 4, PWM x 8	Timer x 4, PWM x 8
12-bit ADC	1 x 10-ch.	1 x 10-ch.	2 x 10-ch.	2 x 10-ch.

Table 1-1 i.MX 6UL Device Options

2. Hardware Characteristics

2.1 CPU Characteristics

2.1.1 CPU Overview

The i.MX 6UL is a high performance, ultra efficient processor family with NXP’s advanced implementation of the single ARM Cortex®-A7 core. It operates at speeds of up to 629 MHz. i.MX 6UL includes integrated power management module that reduces the complexity of external power supply and simplifies the power sequencing. Each processor in this family provides various memory interfaces, including LPDDR2, DDR3, DDR3L, Raw and Managed NAND flash, NOR flash, eMMC, Quad SPI, and a wide range of other interfaces for connecting peripherals, such as WLAN, Bluetooth™, GPS, displays, and camera sensors.

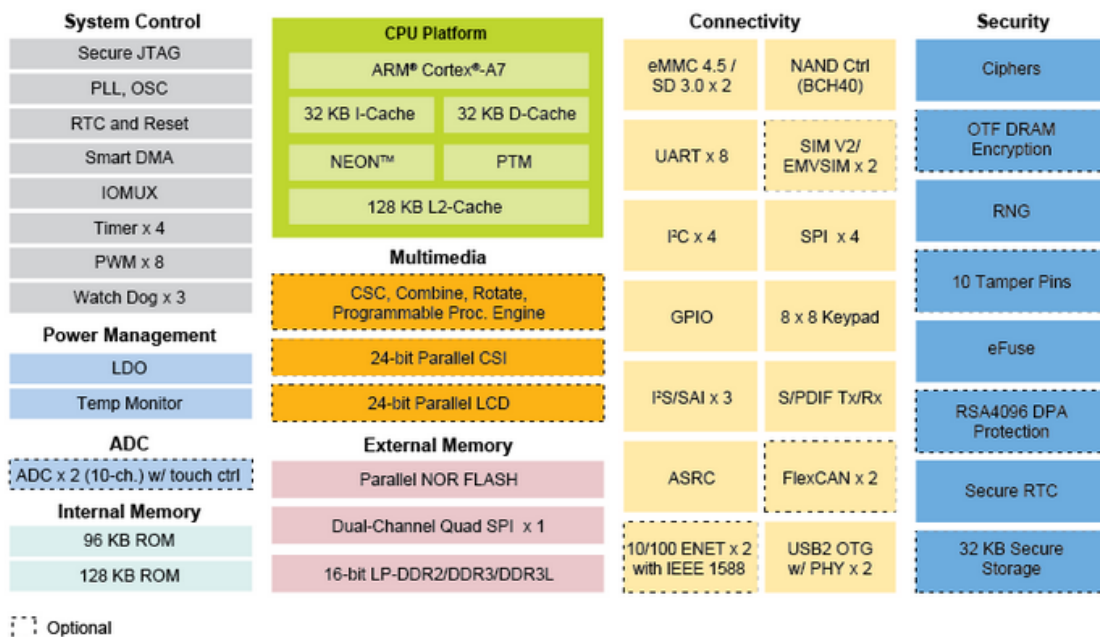

Figure 2-1 i.MX 6UL Block Diagram

2.1.2 CPU Features

- ARM® Cortex®-A7 @ 696 MHz, 128 KB L2 cache
- Parallel LCD Display up to WXGA (1366x768)
- 8/10/16/24-bit Parallel Camera Sensor Interface
- 16-bit LP-DDR2, DDR3/DDR3L
- 8/16-bit Parallel NOR FLASH / PSRAM
- Dual-channel Quad-SPI NOR FLASH
- 8-bit Raw NAND FLASH with 40-bit ECC
- 2x MMC 4.5/SD 3.0/SDIO Port
- 2x USB 2.0 OTG, HS/FS, Device or Host with PHY
- Audio Interfaces include 3x I2S/SAI, S/PDIF Tx/Rx
- 2x 10/100 Ethernet with IEEE 1588
- 2x 12-bit ADC, up to 10 input channel total, with resistive touch controller (4-wire/5-wire)
- Partial PMU Integration
- Security Block: TRNG, Crypto Engine (AES with DPA, TDES/SHA/RSA), Tamper Monitor, Secure Boot, SIMV2/EVMSIM X 2, OTF DRAM
- Encryption, PCI4.0 pre-certification
- 14x14 289MAPBGA 0.8mm pitch
- 9x9 272 MAPBGA 0.5mm pitch

2.2 Board Resource

MYS-6ULX-IND single board computer is integrated with rich peripherals including Ethernet, USB OTG, USB Host, TF Card, User key, LEDs, LCD interface, IO expansion interface and other functions. The board is equipped with 256M byte DDR3L memory,

256MB NAND Flash by default. Other memory configurations (Up to 2GB DDR3, more NandFlash or large EMMC) are optional in volume production.

Please refer to the below Figure 2-1 for detail.

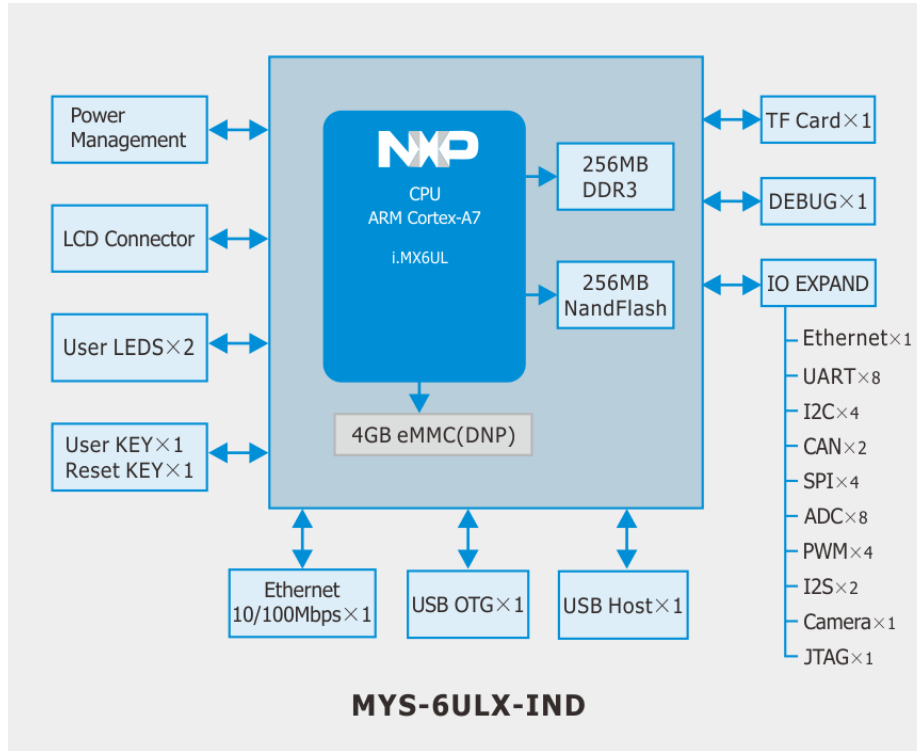

Figure 2-1 Function Block Diagram of MYS-6ULX-IND

2.3 Extend Header Resource

MYS-6ULX-IND single board computer is integrated with rich peripherals. Extended signal pins are available to expand the peripherals. MYS-6ULX-IND provides two 2.0mm pitch 2x20-pin headers to allow users expand other functions.

Please refer to the below for extend header resource.

- 1 x Ethernet
- Up to 46 x GPIO
- Up to 8 x UART
- Up to 4 x I2C
- 2 x CAN
- Up to 4 x SPI
- Up to 8 x ADC Input
- Up to 4 x PWM

- 2 x I2S
- 1 x Camera
- 1 x JTAG

The list is showing the maximum number of the specific interface possible, but due to the reused pin definition, customer will need to refer the PIN definition for signal configuration.

3. Interfaces

Rich peripheral interface resources are provided on the MYS-6ULX-IND single board computer. Detailed resources and the location on the board provided as below.

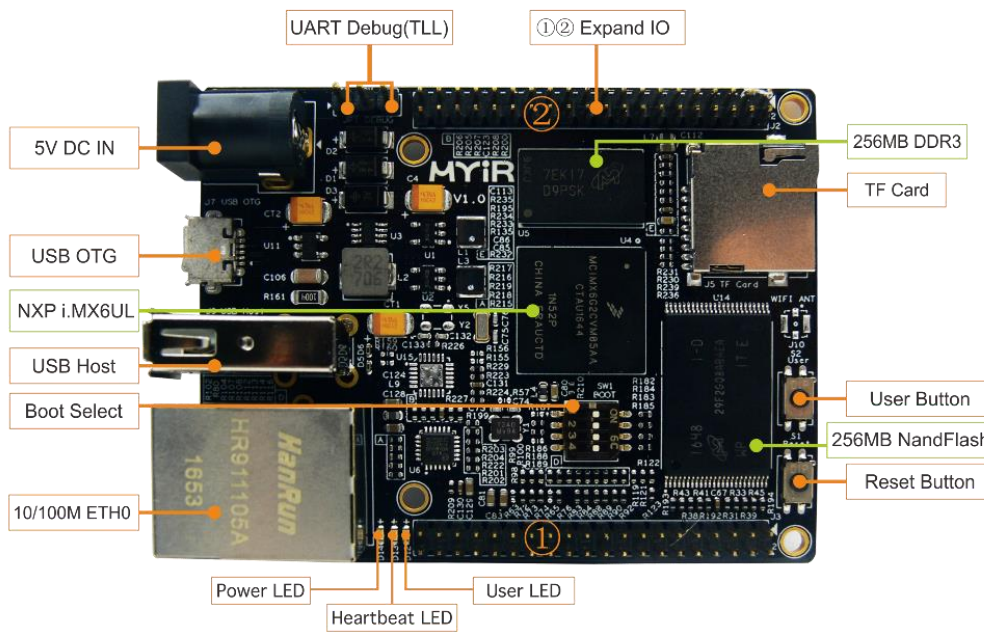

Figure 3-1 MYS-6ULX-IND Resources

Please refer to the interface list as below.

Interface	Designator	Description
Power In	J1	5V DC Power Input
USB Host	J9	USB2.0 Host (Type A) Interface
USB OTG	J7	USB2.0 OTG(Micro Type AB) Interface
Ethernet	CN1	10/100M Ethernet

Processor	U4	MCIMX6Y2DVM05AA (Optional)
NAND Flash	U14	256MB 8Bit (Optional)
DDR	U5	256MB 16 Bit DDR3L (Optional)
Debug UART	JP1	Debug UART (LVTTTL Level)
LCD	J8	24 Bit LCD& Touch Panel Interface
Buttons	S1	System Reset
	S2	User Button
LEDs	D14	5V Power LED
	D12	User LED1
	D13	User LED2
Extend Header	J2	Expansions for SPI,I2C,UART,Camera and ETH signal
	J3	
TF Card	J5	Micro SD Card Socket
Switch	SW1	Boot Configure Switch

Table 3-1 List of MYS-6ULX-IND Resources

4. Hardware Design

4.1 Power supply

i.MX 6UL includes integrated power management module that reduces the complexity of external power supply and simplifies the power sequencing. It is easy to implement the power supply unit via discrete device.

Based on the datasheet of i.MX 6UL, the CPU power can be summarized to 5 power rails, which are as below Table 4-1.

Item	Voltage	Power Rail
1	3.3V	VDD_HIGH_IN, NVCC_xxx, VDDA_ADC_3P3
2	1.2V	VDD_SOC_IN
3	1.35V	NVCC_DRAM
4	3.0V	VDD_SNVS_IN
5	5V	USB_OTGx_VBUS

Table 4-1 I.MX6 ULL Power rail

MYS-6ULX-IND single board computer is designed to offer power via discrete device circuit instead of the power management IC. Please refer to below power tree for detail.

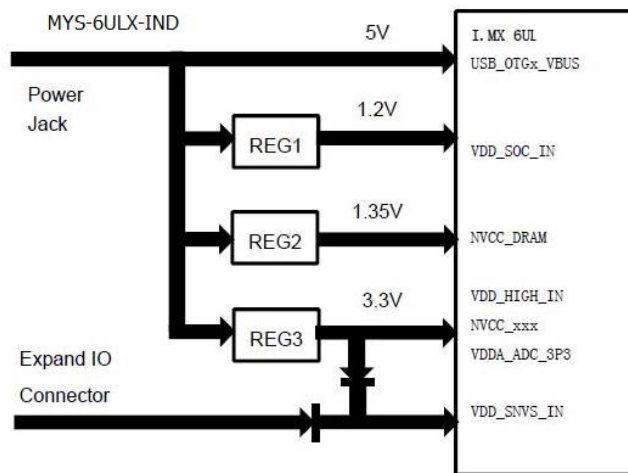

Figure 4-1 MYS-6ULX-IND Power Tree

4.2 Clock Resources

MYS-6ULX-IND includes three CPU clocks,

- 24 Mhz CPU main clock (Y1)
- 32.768 Khz CPU RTC clock(Y2)
- 24 Mhz USB HUB Clock(Y5)

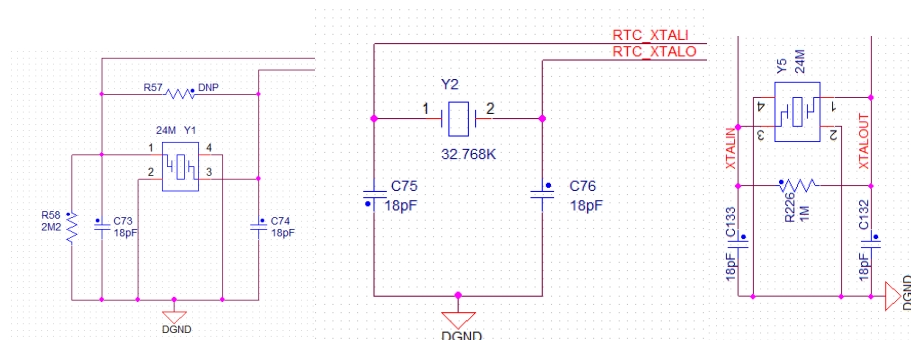

Figure 4-2 Clock Resources

4.3 DDR3L SDRAM

MYS-6ULX-IND single board computer is equipped with a 256MB (128Mx 16Bit) DDR3L SDRAM Memory. The part number is MT41K128M16JT-125 IT from micron. The working frequency is up to 400MHZ with bandwidth of 16bit, and the DDR size is up to 2G byte.

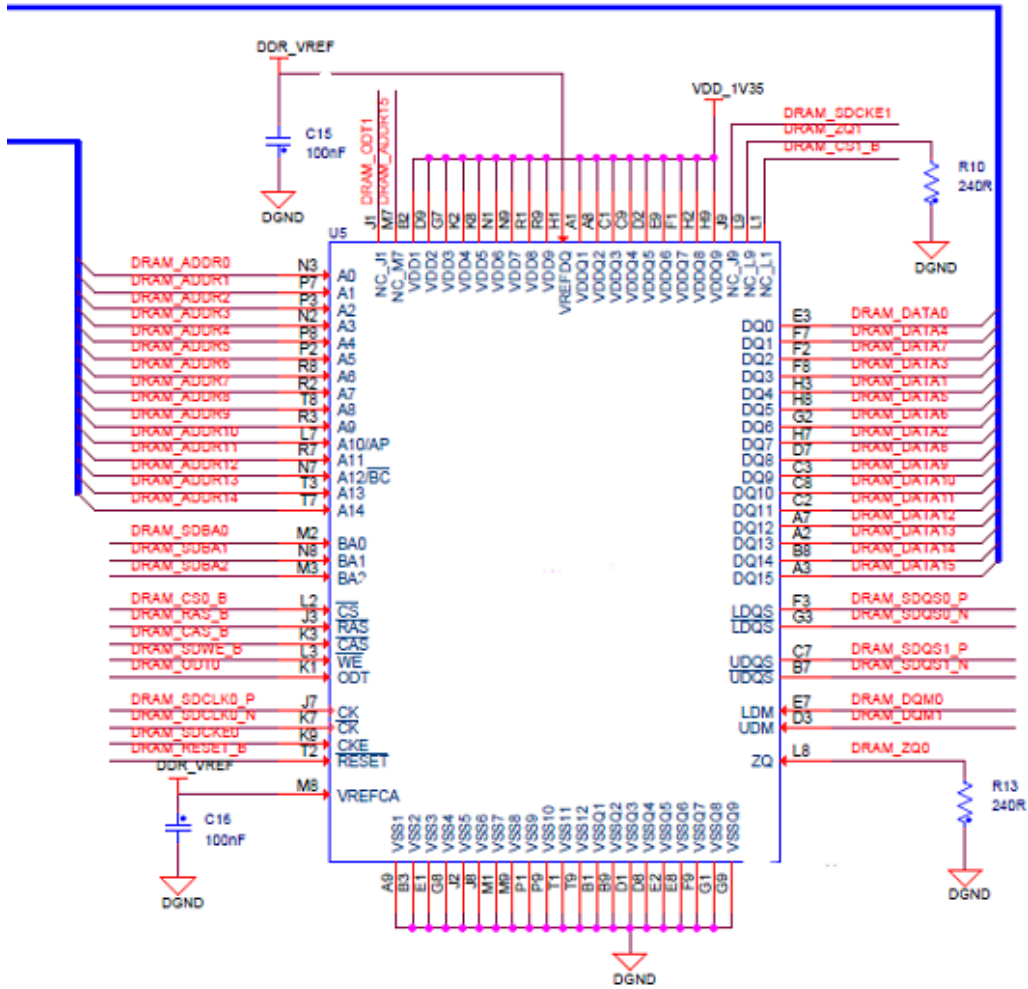

Figure 4-3 DDR3L SDRAM

4.4 eMMC Memory

MYS-6ULX-IND is designed to support both NAND Flash and eMMC on PCB design. eMMC is DNP on-board in default, while 256MB NAND Flash is the default memory configuration for the board. Customer can choose to remove the NAND Flash and assemble eMMC for R&D purpose, or get MYiR to customize on volume production. The eMMC Memory is connected to SD2 port of i.MX 6UL(8bit bandwidth). A reference design of using 4GB EMMC(Micron, MTFC4GACAAAM-4M IT) as below.

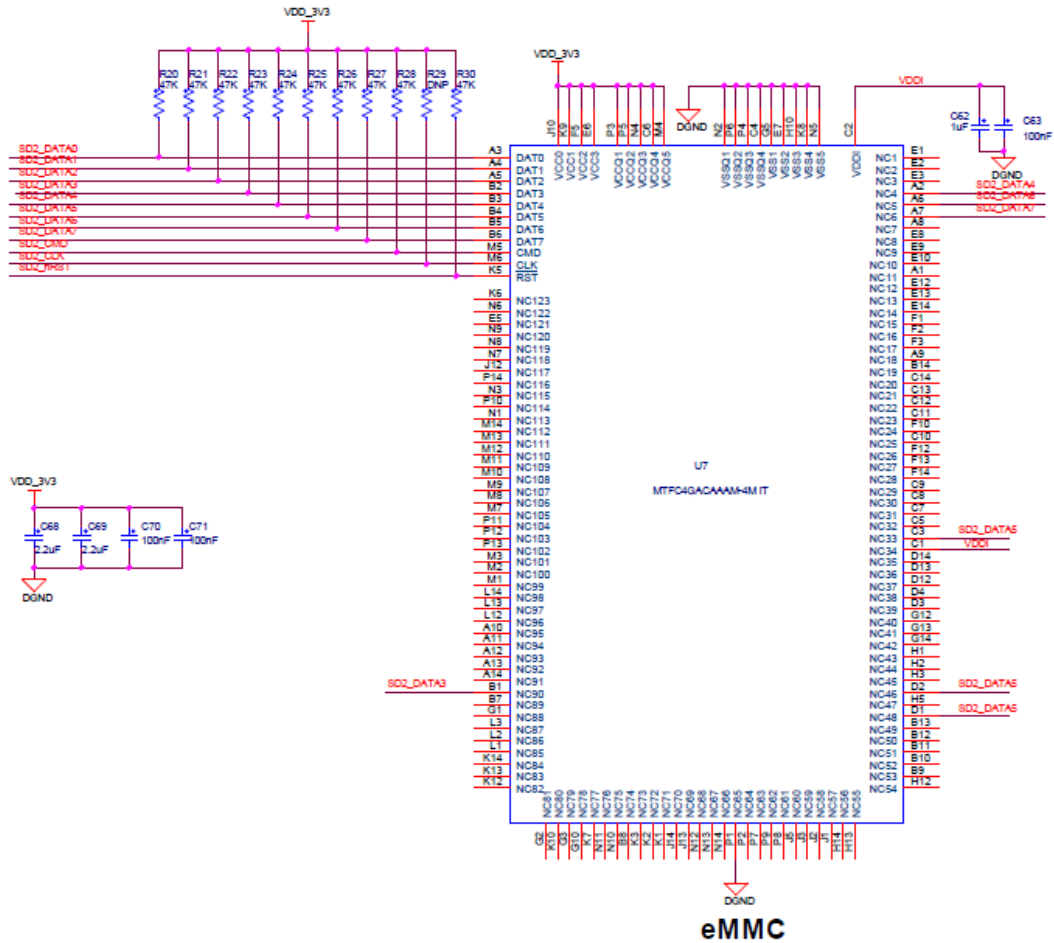
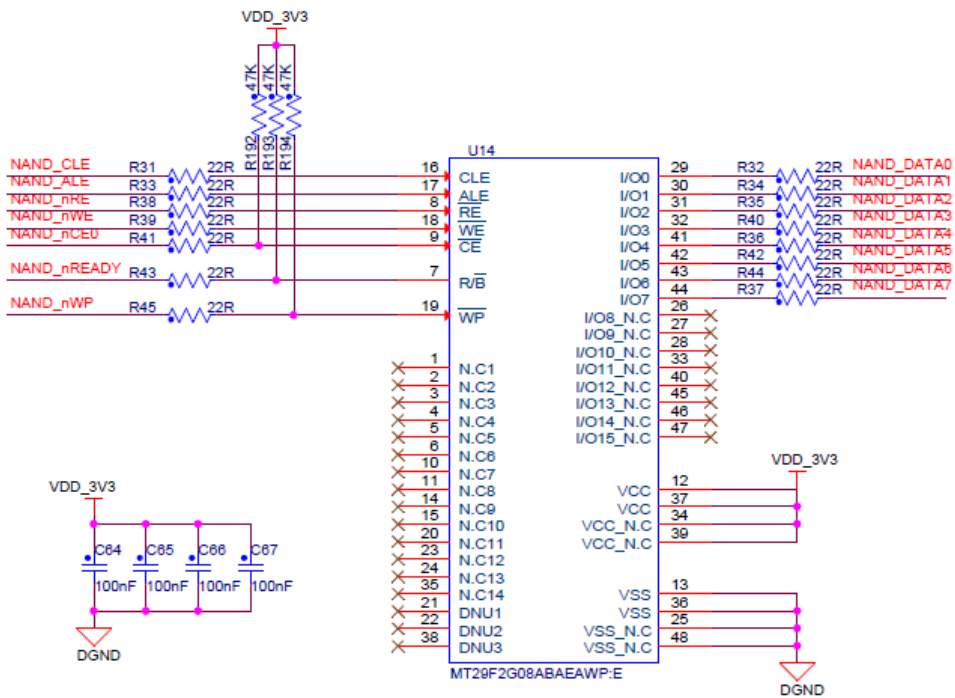

Figure 4-4 eMMC Memory

4.5 NAND Flash Memory

MYS-6ULX-IND is designed to support both NAND Flash and eMMC on PCB design. One NAND Flash with 256MB is connected to the GPML controller of the processor in default. The part number is MT29F2G08ABAEAWP-IT:E from Micron. It can be used to store the system booting code and other information.



Nand Flash

Figure 4-5 NAND Flash

4.6 Ethernet

MYS-6ULX-IND is equipped with a Ethernet operating at 10/100 Mb/s, which offering a standard RJ45 connection (With voltage transformer inside the socket). The PHY silicon with part number of LAN8720AI-CP from Microchip is used. The PHY address of MIDO bus is 0. Please refer to the schematic of the Ethernet of the board as below.

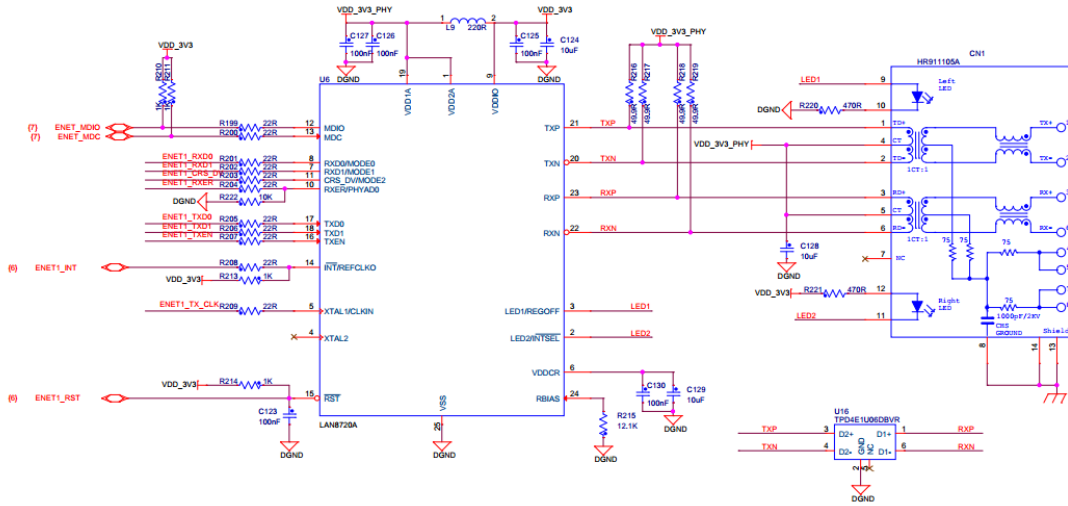

Figure 4-6 Ethernet

4.7 Micro SD Card

I.MX6UL processor provides two MMC/SD/SDIO card ports. Port SD2 has been connected to the eMMC, and port SD1 is connected to a micro SD card connector (4 bit mode) on the MYS-6ULX-IND. It can be used to store the system booting code and other information using a micro SD card memory.

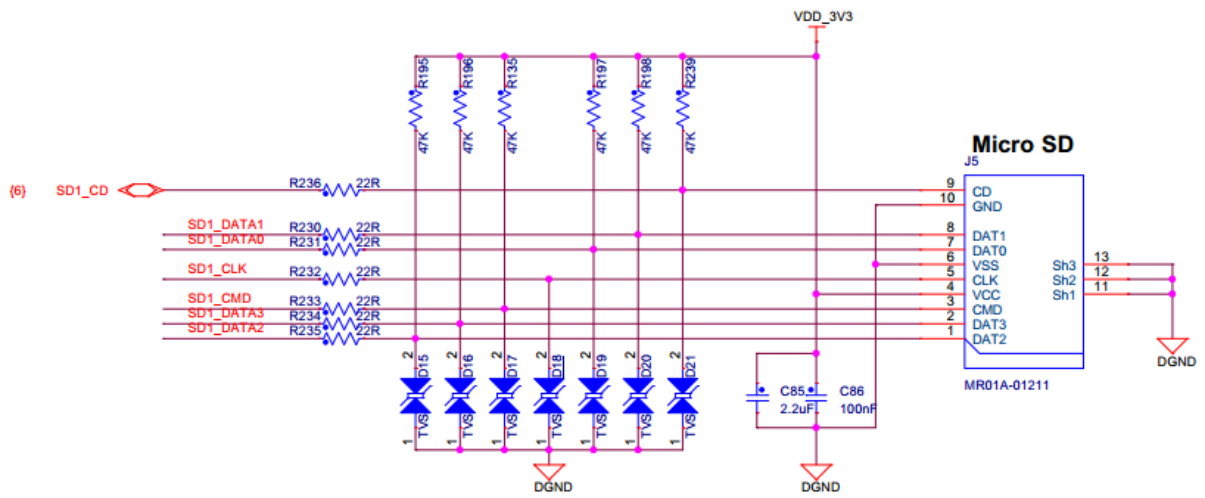

Figure 4-7 Micro SD Card

4.8 LCD & Touch Panel Interface

i.MX6UL processor provides one parallel display port, support max 85 MHz display clock and up to WXGA (1366 x 768) at 60 Hz. A 50 pins FPC connector have been used for the display port on the MYS-6ULX-IND.Linux drivers are provided to work with MIYR LCD panels for 4.3 inch LCD(480*272) and 7 inch LCD(800*480).Resistance and capacitance touch panel are supported.Please refer to below for detail design of LCD interface.

If you need more information on the LCD panels,please visit www.myrtech.com.

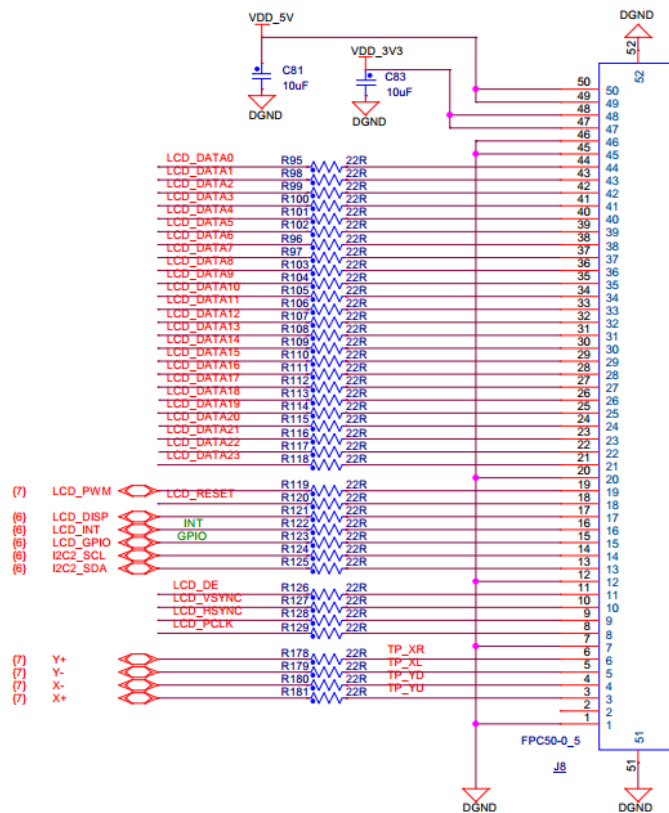

Figure 4-8 LCD & Touch Panel Interface

4.9 USB

i.MX6UL processor provides two high speed (HS) USB 2.0 OTG (Up to 480 Mbps), with integrated HS USB PHY.OTG1 port is connected to a standard micro USB OTG connector (Type AB),which can be used as host and slave. OTG2 is connected to a standard USB host connector (Type A).Please refer to the schematic of the USB OTG connector of the board as below.

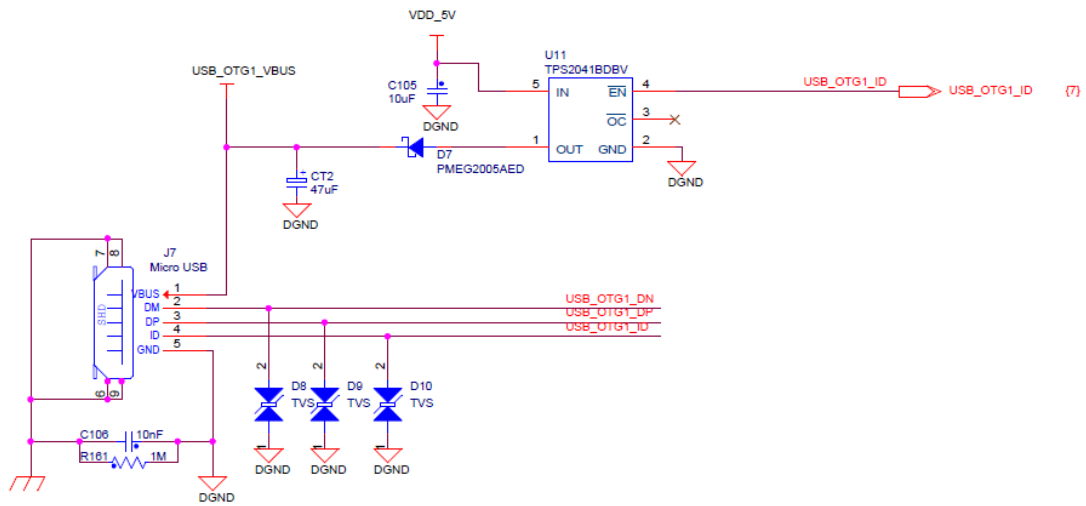

Figure 4-9 USB OTG

Refer to the schematic of USB Host as below.

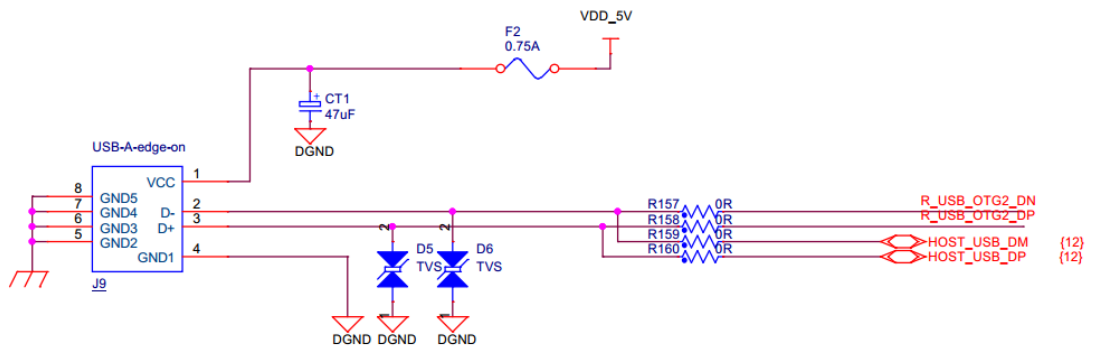

Figure 4-10 USB Host

4.10 Button & LEDs

MYS-6ULX-IND is equipped with a user button. Please refer to the schematic of the button as below.

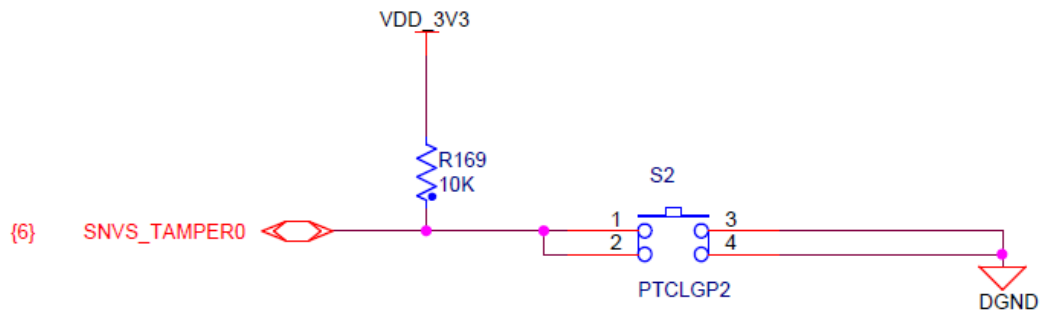

Figure 4-11 User Button

MYS-6ULX-IND is equipped with two user LEDs. Please refer to the schematic of the LEDs as below.

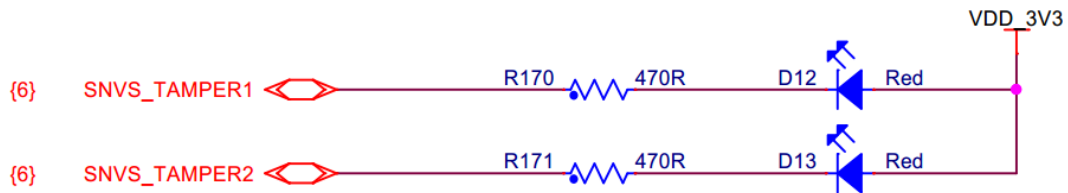

Figure 4-12 User LEDs

4.11 Boot Configure

The boot process begins at the Power-On Reset (POR) where the hardware reset logic forces the ARM core to begin the execution starting from the on-chip boot ROM. The boot ROM code uses the state of the internal register BOOT_MODE[1:0] as well as the state of various eFUSES and/or GPIO settings to determine the boot flow behavior of the device.

MYS-6ULX-IND is equipped with a 4 bit switch to change the boot device.

Please refer to the schematic for the boot state as below.

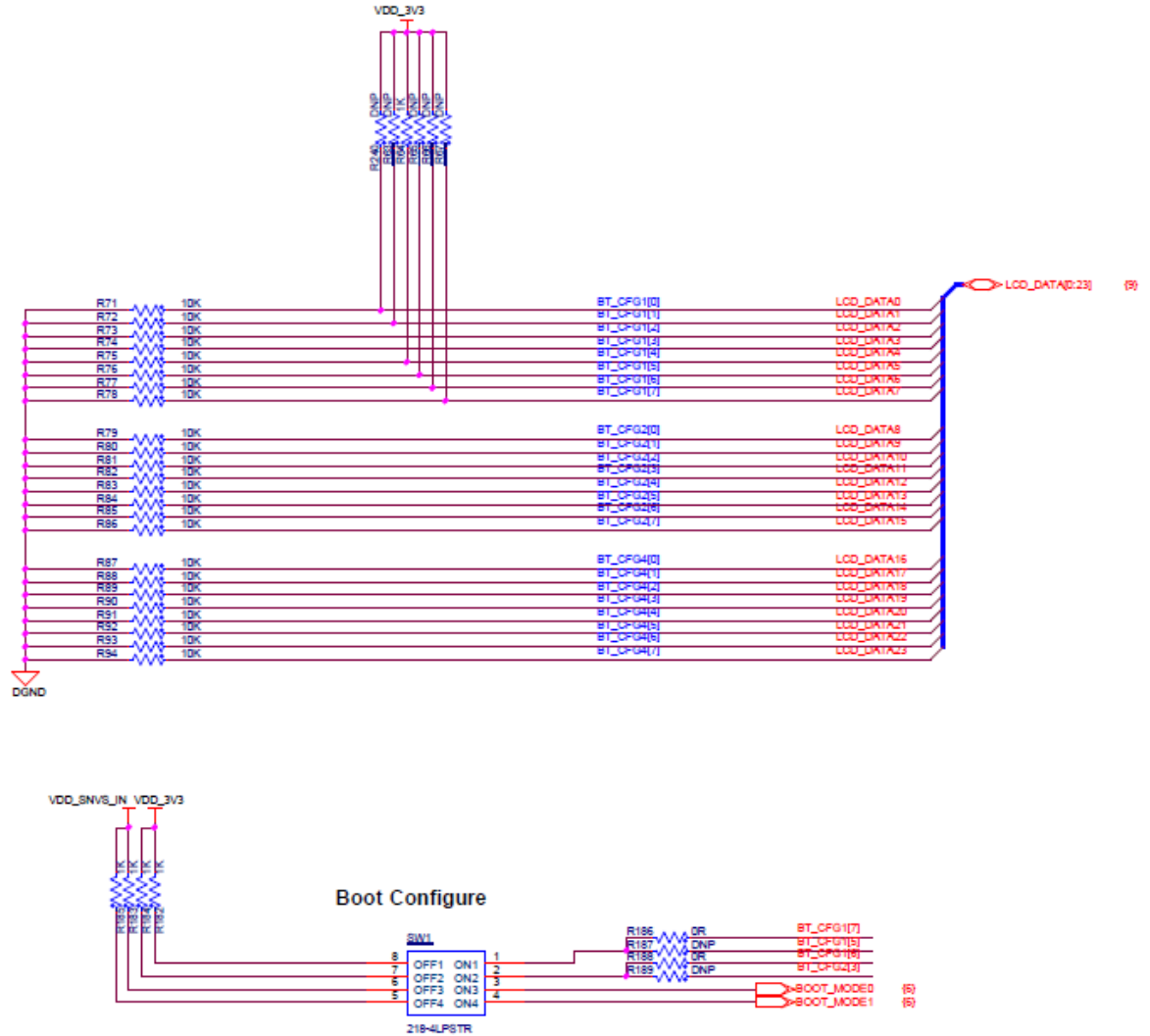

Figure 4-13 Boot Configure

There are some differences between the NAND Flash version and the eMMC version in the boot Configure.

Bit1 and Bit2 is used to select boot device. Please refer NAND Flash version setting as below.

Switch	BIT1	BIT2
SD Card	0	1
NAND Flash	1	0

Table 4-2 NAND Flash Version Boot Configure

Please refer eMMC version setting as below.

Switch	BIT1	BIT2
SD Card	0	0
eMMC	1	1

Table 4-3 eMMC Version Boot Configure

Bit3 and Bit4 is used to select boot type, please refer the setting as below,

Switch		Boot Type
BIT4	BIT3	
0	0	Boot From Fuses
0	1	Serial Downloader
1	0	Internal Boot
1	1	Reserved

Table 4-4 Boot Type Configure

4.12 Expansion Interface

MYS-6ULX-IND is equipped with two pin header (40 pins with 2.00mm pitch), where up to 46 free GPIOs have been provided. Those GPIOs also can be used as other functions, such as SPI, QSPI, UART, I2C, and so on.

Please refer to the schematic of Expansion Interfaces as below, and please be noticed to refer to i.MX6UL data-sheet for PIN configuration.

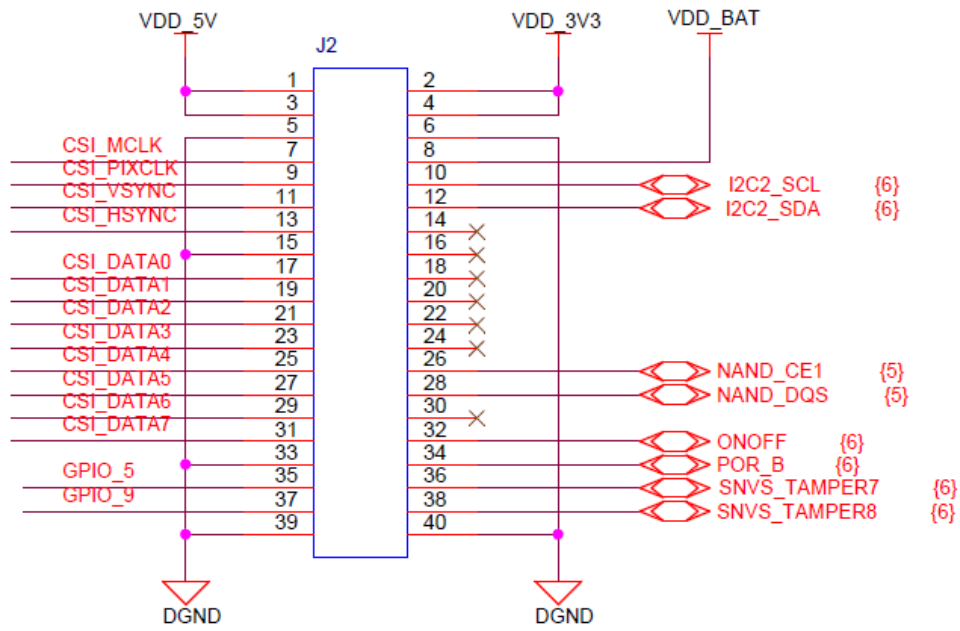

Figure 4-14 Expansion Interface (J2)

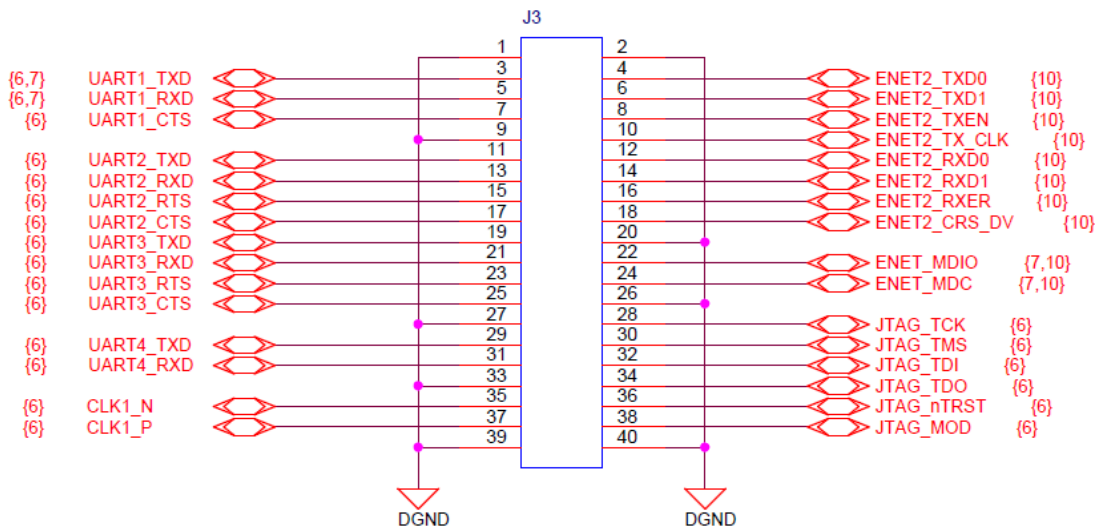

Figure 4-15 Expansion Interface (J3)

4.13 Debug UART

MYS-6ULX-IND is equipped with a debug UART, which can be used as Linux terminal to debug the system. A pin header (1x3pins, 2.54mm pitch) has been used for the debug UART port. The debug UART is 3.3V LVTTTL Level standard. Consumers can use it with a

USB to UART (TTL level) cable. MIYR provides suitable cable for selection. For more detail, please visit <http://www.myirtech.com/list.asp?id=537> .

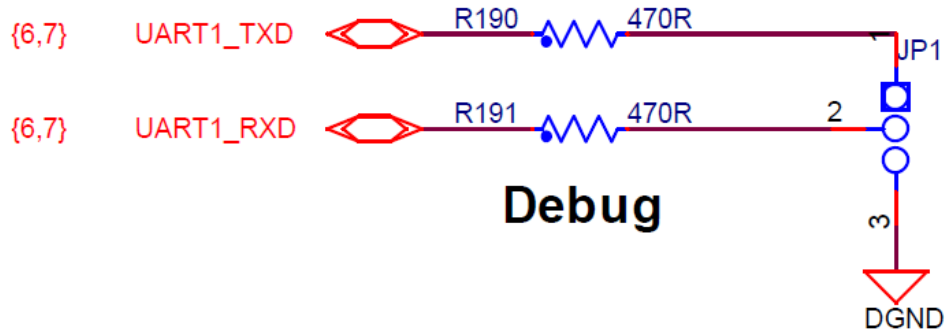

Figure 4-16 Debug UART

5. Electronic Characteristics

5.1 Operating Temperature

Application Scenarios	Parameter				Des.
	MIN	Nor.	Max	Unit	
Commercial Level	-40	—	+85	°C	—

Table 5-1 Operating Temperate

5.2 Power Supply Characteristics

Item	Label	Parameter				Description
		MIN	Normal	MAX	Unit	
System Voltage	5V	4.8	5.0	5.5	V	Power In
System Current	I _{v5.0}	---	0.26	---	A	Linux system, No LCD
RTC Voltage	VDD_BAT	2.4	--	3.6	V	RTC Power In

Table 5-2 Power Supply Characteristics

5.3 GPIO DC Characteristics

Item	Label	Parameter				Description
		MIN	Normal	MAX	Unit	
Input High Voltage	V _{IH}	2.3	--	3.3	V	--
Input Low Voltage	V _{IL}	0	--	0.99	V	--
Output high Voltage	V _{OH}	3.15	---	--	V	--
Output Low Voltage	V _{OL}	--	--	0.15	V	--

Table 5-3 GPIO DC Characteristics

6. Mechanical Characteristics

- ◆ PCB Layers
8 Layers PCB, Immersion Gold Process, Lead-Free
- ◆ Mechanical
70x55x17.5mm

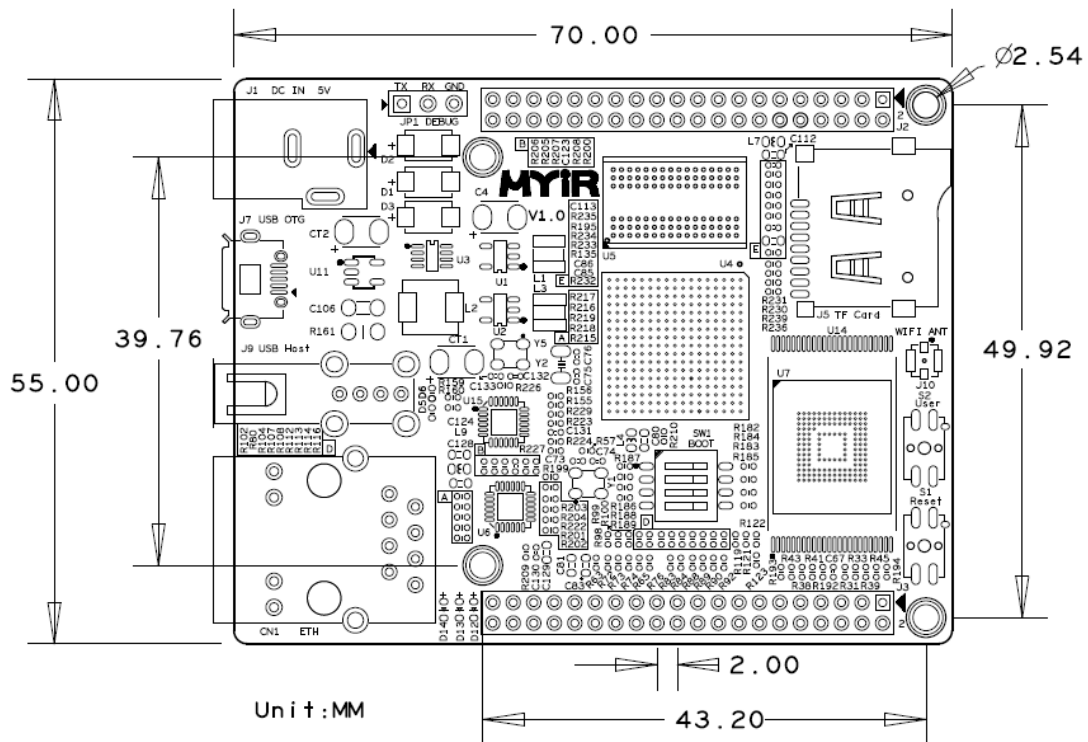

Figure 6-1 Mechanical Information of MYS-6ULX-IND

For more details about the board, please refer to the DXF file.

Appendix 1 Warranty & Technical Support Services

MYIR Tech Limited is a global provider of ARM hardware and software tools, design solutions for embedded applications. We support our customers in a wide range of services to accelerate your time to market.

MYIR is an ARM Connected Community Member and work closely with ARM and many semiconductor vendors. We sell products ranging from board level products such as development boards, single board computers and CPU modules to help with your evaluation, prototype, and system integration or creating your own applications. Our products are used widely in industrial control, medical devices, consumer electronic, telecommunication systems, Human Machine Interface (HMI) and more other embedded applications. MYIR has an experienced team and provides custom design services based on ARM processors to help customers make your idea a reality.

The contents below introduce to customers the warranty and technical support services provided by MYIR as well as the matters needing attention in using MYIR's products.

Service Guarantee

MYIR regards the product quality as the life of an enterprise. We strictly check and control the core board design, the procurement of components, production control, product testing, packaging, shipping and other aspects and strive to provide products with best quality to customers. We believe that only quality products and excellent services can ensure the long-term cooperation and mutual benefit.

Price

MYIR insists on providing customers with the most valuable products. We do not pursue excess profits which we think only for short-time cooperation. Instead, we hope to establish long-term cooperation and win-win business with customers. So we will offer reasonable prices in the hope of making the business greater with the customers together hand in hand.

Delivery Time

MYIR will always keep a certain stock for its regular products. If your order quantity is less than the amount of inventory, the delivery time would be within three days; if your order quantity is greater than the number of inventory, the delivery time would be always four to six weeks. If for any urgent delivery, we can negotiate with customer and try to supply the goods in advance.

Technical Support

MYiR has a professional technical support team. Customer can contact us by email (support@myirtech.com), we will try to reply you within 48 hours. For mass production and customized products, we will specify person to follow the case and ensure the smooth production.

After-sale Service

MYiR offers one year free technical support and after-sales maintenance service from the purchase date. The service covers:

1. Technical support service

- a) MYiR offers technical support for the hardware and software materials which have provided to customers;
- b) To help customers compile and run the source code we offer;
- c) To help customers solve problems occurred during operations if users follow the user manual documents;
- d) To judge whether the failure exists;
- e) To provide free software upgrading service.

However, the following situations are not included in the scope of our free technical support service:

- a) Hardware or software problems occurred during customers' own development;
- b) Problems occurred when customers compile or run the OS which is tailored by themselves;
- c) Problems occurred during customers' own applications development;
- d) Problems occurred during the modification of MYiR's software source code.

2. After-sales maintenance service

The products except LCD, which are not used properly, will take the twelve months free maintenance service since the purchase date. But following situations are not included in the scope of our free maintenance service:

- a) The warranty period is expired;
- b) The customer cannot provide proof-of-purchase or the product has no serial number;
- c) The customer has not followed the instruction of the manual which has caused the damage the product;
- d) Due to the natural disasters (unexpected matters), or natural attrition of the components, or unexpected matters leads the defects of appearance/function;

- e) Due to the power supply, bump, leaking of the roof, pets, moist, impurities into the boards, all those reasons which have caused the damage of the products or defects of appearance;
- f) Due to unauthorized weld or dismantle parts or repair the products which has caused the damage of the products or defects of appearance;
- g) Due to unauthorized installation of the software, system or incorrect configuration or computer virus which has caused the damage of products.

Warm tips:

- 1) MYIR does not supply maintenance service to LCD. We suggest the customer first check the LCD when receiving the goods. In case the LCD cannot run or no display, customer should contact MYIR within 7 business days from the moment get the goods.
- 2) Please do not use finger nails or hard sharp object to touch the surface of the LCD.
- 3) MYIR suggests user purchasing a piece of special wiper to wipe the LCD after long time use, please avoid clean the surface with fingers or hands to leave fingerprint.
- 4) Do not clean the surface of the screen with chemicals.
- 5) Please read through the product user manual before you using MYIR's products.
- 6) For any maintenance service, customers should communicate with MYIR to confirm the issue first. MYIR's support team will judge the failure to see if the goods need to be returned for repair service, we will issue you RMA number for return maintenance service after confirmation.

3. Maintenance period and charges

- a) MYIR will test the products within three days after receipt of the returned goods and inform customer the testing result. Then we will arrange shipment within one week for the repaired goods to the customer. For any special failure, we will negotiate with customers to confirm the maintenance period.
- b) For products within warranty period and caused by quality problem, MYIR offers free maintenance service; for products within warranty period but out of free maintenance service scope, MYIR provides maintenance service but shall charge some basic material cost; for products out of warranty period, MYIR provides maintenance service but shall charge some basic material cost and handling fee.

4. Shipping cost

During the warranty period, the shipping cost which delivered to MYIR should be responsible by user; MYIR will pay for the return shipping cost to users when the product is repaired. If the warranty period is expired, all the shipping cost will be responsible by users.

5. Products Life Cycle

MYIR will always select mainstream chips for our design, thus to ensure at least ten years continuous supply; if meeting some main chip stopping production, we will inform customers in time and assist customers with products updating and upgrading.

Value-added Services

1. MYIR provides services of driver development base on MYIR's products, like serial port, USB, Ethernet, LCD, etc.
2. MYIR provides the services of OS porting, BSP drivers' development, API software development, etc.
3. MYIR provides other products supporting services like power adapter, LCD panel, etc.
4. ODM/OEM services.



MYIR Tech Limited

Room 1306, Wensheng Center, Wenjin Plaza,

North Wenjin Road, Luohu District, Shenzhen, China 518020

Support Email: support@myirtech.com

Sales Email: sales@myirtech.com

Phone: +86-755-22984836

Fax: +86-755-25532724

Website: www.myirtech.com